

Product: TT100 Full Extension Ball-Bearing Drawer Slide
Mounting: Side
Clearance: 1/2" [12.7mm +.8mm minus 0]
Load Class: 100 lb.
Height: 1.79" [45.5mm (±0.3)]
Finish: Zinc
Action: Full Extension (sizes: 12" – 28")
Sizes: 10" [250mm], 12" [300mm], 14" [350mm], 16" [400mm], 18" [450mm], 20" [500mm], 22" [550mm], 24" [600mm], 26" [650mm], 28" [700mm]

Max. Recommended Drawer Width: 24"

Packaging: 10 Pair and 1 set of instructions per box. Mounting hardware not included
 Slides are unhandled

Optional: Rear Mounting Brackets:
 TT401A 200 (10 inner boxes of 20 brackets)
 TT401AB 200 (200 loose brackets)

Part Number	Size	Slide Length	Slide Travel	A	B	C	D
TT100B 250	10"	250mm [9.84"]	250mm [9.84"]	—	—	—	—
TT100B 300	12"	300mm [11.81"]	300mm [11.81"]	224mm [8.82"]	—	—	—
TT100B 350	14"	350mm [13.78"]	350mm [13.78"]	—	—	128mm [5.04"]	256mm [10.08"]
TT100B 400	16"	400mm [15.75"]	400mm [15.75"]	288mm [11.34"]	—	160mm [6.30"]	320mm [12.60"]
TT100B 450	18"	450mm [17.72"]	450mm [17.72"]	352mm [13.86"]	—	160mm [6.30"]	352mm [13.86"]
TT100B 500	20"	500mm [19.69"]	500mm [19.69"]	352mm [13.86"]	416mm [16.38"]	192mm [7.56"]	416mm [16.38"]
TT100B 550	22"	550mm [21.65"]	550mm [21.65"]	352mm [13.86"]	416mm [16.38"]	224mm [8.82"]	448mm [17.64"]
TT100B 600	24"	600mm [23.62"]	600mm [23.62"]	224mm [8.82"]	352mm [13.86"]	480mm [18.90"]	256mm [10.08"]
TT100B 650	26"	650mm [25.29"]	650mm [25.29"]	224mm [8.82"]	352mm [13.86"]	544mm [21.42"]	288mm [11.34"]
TT100B 700	28"	700mm [27.56"]	700mm [27.56"]	224mm [8.82"]	352mm [13.86"]	544mm [21.42"]	288mm [11.34"]

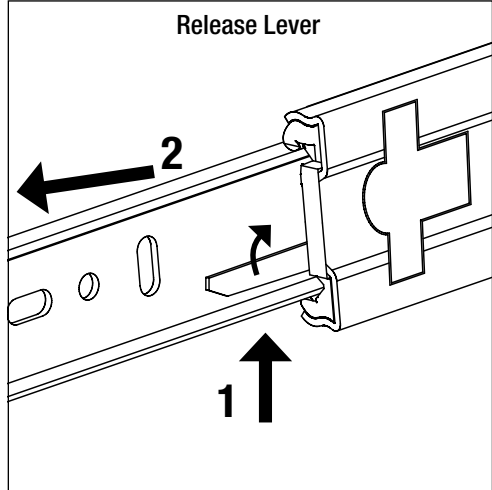
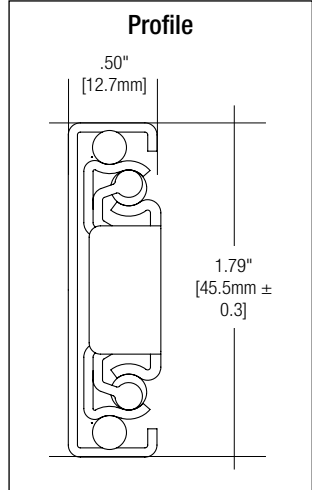
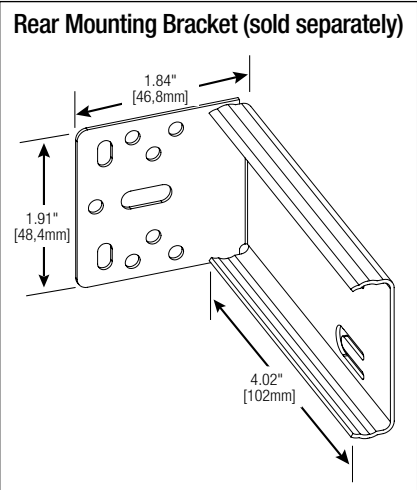

Warranty Information

KV Tru-Trac™ offers a One Year Limited Warranty to the initial purchaser of this product. This warranty covers defects in materials and workmanship, which occur during normal use, and the remedy is limited to only repair or replacement of the defective product, at Tru-Trac's option. This warranty does not apply to defects resulting from misuse, damage or abuse, normal wear and tear, accident, modification, improper installation or maintenance, third party materials or damage during shipping.

For warranty service, please contact Tru-Trac, PO Box 150047, Grand Rapids, Michigan 49515-0047. Any defective product must be returned postage or freight prepaid to Tru-Trac and must include a claimed defect and date of purchase.

THIS ONE YEAR LIMITED WARRANTY CONSTITUTES THE ONLY WARRANTY AND SOLE REMEDY FOR THE PRODUCTS AND ALL OTHER WARRANTIES OR REPRESENTATIONS ARE HEREBY EXPRESSLY DISCLAIMED.