

Polymer Sink Front Trays & Hinge Kits

- 1-5/8" deep tray is ideal for solid surface countertops with large deep sink applications
- For use with face frame or frameless (Euro-Style) cabinetry
- Two trays, two pairs of Scissor Hinges (SH-1) with hardware and instructions included



PSF14SH-2-W
(Hinges included)



PSF11SH-2-W
(Hinges included)

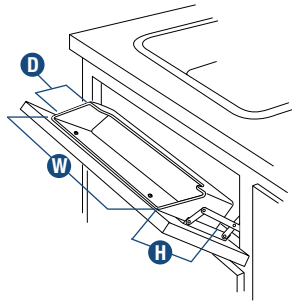

Polymer Sink Front Tray & Hinge Kit

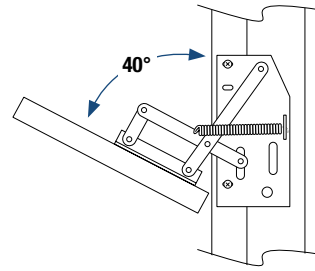

Scissor Hinge
(SH-10)



Kits include 2 pairs of Scissor Hinges (SH-10)

See page 47 for minimum drawer dimensions.

Stock #	Height H	Width W	Depth D	Finish	Kits per Carton	Weight per Carton
POLYMER SINK FRONT TRAYS & HINGE KITS						
PSF8.62SH-2-W	3" [76 mm]	8-5/8" [219 mm]	2" [51 mm]	White	10	1.1 lbs. [0.5 kg.]
PSF11-PF-SH-2-W	3" [76 mm]	11" [279 mm]	1-5/8" [41 mm]	White	10	1.6 lbs. [0.7 kg.]
PSF11SH-2-W	3" [76 mm]	11" [279 mm]	2" [51 mm]	White	40	1.8 lbs. [0.8 kg.]
PSF14-PF-SH-2-W	3" [76 mm]	14" [356 mm]	1-5/8" [41 mm]	White	10	2.0 lbs. [0.9 kg.]
PSF14SH-2-W	3" [76 mm]	14" [356 mm]	2" [51 mm]	White	21	2.2 lbs. [1.0 kg.]

Cabinet Dimensions

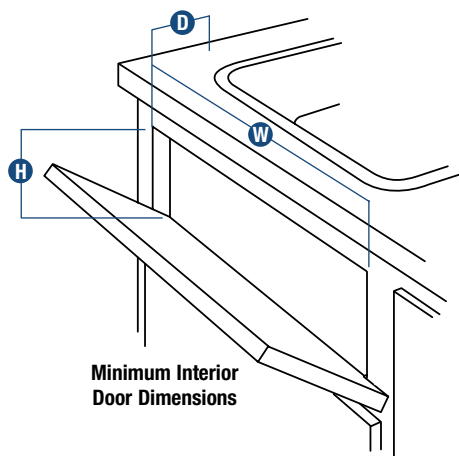

Stock #	Height H	Width W	Depth D
POLYMER SINK FRONT TRAYS & HINGE KITS (dimensions include hinge kits)			
PSF8.62SH-2-A	3-1/2" [89 mm]	10-1/8" [257 mm]	2-1/2" [64 mm]
PSF8.62SH-2-W	3-1/2" [89 mm]	10-1/8" [257 mm]	2-1/2" [64 mm]
PSF11-PF-SH-2-A	3-1/2" [89 mm]	12-1/2" [318 mm]	2-1/8" [54 mm]
PSF11-PF-SH-2-W	3-1/2" [89 mm]	12-1/2" [318 mm]	2-1/8" [54 mm]
PSF11SH-2-A	3-1/2" [89 mm]	12-1/2" [318 mm]	2-1/2" [64 mm]
PSF11SH-2-W	3-1/2" [89 mm]	12-1/2" [318 mm]	2-1/2" [64 mm]
PSF14-PF-SH-2-A	3-1/2" [89 mm]	15-1/2" [394 mm]	2-1/8" [54 mm]
PSF14-PF-SH-2-W	3-1/2" [89 mm]	15-1/2" [394 mm]	2-1/8" [54 mm]
PSF14SH-2-A	3-1/2" [89 mm]	15-1/2" [394 mm]	2-1/2" [64 mm]
PSF14SH-2-W	3-1/2" [89 mm]	15-1/2" [394 mm]	2-1/2" [64 mm]
POLYMER SINK FRONT TRAYS (with stops)			
PSF11W-W	3-1/2" [89 mm]	11-1/2" [292 mm]	3-1/4" [83 mm]
PSF14W-A	3-1/2" [89 mm]	14-1/2" [368 mm]	3-1/4" [83 mm]
PSF14W-W	3-1/2" [89 mm]	14-1/2" [368 mm]	3-1/4" [83 mm]
SCISSOR HINGES			
SH-1-S/P	4-1/16" [103 mm]	3-1/8" [79 mm]	2-3/8" [60 mm]
SH-10	4-1/16" [103 mm]	3-1/8" [79 mm]	2-3/8" [60 mm]
SH-40	4-1/16" [103 mm]	3-1/8" [79 mm]	2-3/8" [60 mm]
EURO-TRAY HINGES			
ET-H-N	3-1/8" [79 mm]	4" [102 mm]	2-3/4" [70 mm]

Stock #	Height H	Width W (with Scissor Hinges)	Width W (with Euro-Tray Hinges)	Depth D
POLYMER SINK FRONT TRAYS				
PSF8.62-A	3-1/2" [89 mm]	10-1/8" [257 mm]	12-7/8" [327 mm]	2-1/2" [64 mm]
PSF8.62-W	3-1/2" [89 mm]	10-1/8" [257 mm]	12-7/8" [327 mm]	2-1/2" [64 mm]
PSF11-A	3-1/2" [89 mm]	12-1/2" [318 mm]	15-1/4" [387 mm]	2-1/2" [64 mm]
PSF11-PF-A	3-1/2" [89 mm]	12-1/2" [318 mm]	15-1/4" [387 mm]	2-1/8" [54 mm]
PSF11-PF-W	3-1/2" [89 mm]	12-1/2" [318 mm]	15-1/4" [387 mm]	2-1/8" [54 mm]
PSF11-W	3-1/2" [89 mm]	12-1/2" [318 mm]	15-1/4" [387 mm]	2-1/2" [64 mm]
PSF11RS-A	3-1/2" [89 mm]	12-1/2" [318 mm]	15-1/4" [387 mm]	2-1/2" [64 mm]
PSF11RS-W	3-1/2" [89 mm]	12-1/2" [318 mm]	15-1/4" [387 mm]	2-1/2" [64 mm]
PSF14-A	3-1/2" [89 mm]	15-1/2" [394 mm]	18-1/4" [464 mm]	2-1/2" [64 mm]
PSF14-PF-A	3-1/2" [89 mm]	15-1/2" [394 mm]	18-1/4" [464 mm]	2-1/8" [54 mm]
PSF14-PF-W	3-1/2" [89 mm]	15-1/2" [394 mm]	18-1/4" [464 mm]	2-1/8" [54 mm]
PSF14-W	3-1/2" [89 mm]	15-1/2" [394 mm]	18-1/4" [464 mm]	2-1/2" [64 mm]
PSF14RS-A	3-1/2" [89 mm]	15-1/2" [394 mm]	18-1/4" [464 mm]	2-1/2" [64 mm]
PSF14RS-W	3-1/2" [89 mm]	15-1/2" [394 mm]	18-1/4" [464 mm]	2-1/2" [64 mm]
PSF2425-A	3-1/2" [89 mm]	25-7/8" [657 mm]	28-5/8" [727 mm]	2-1/2" [64 mm]
PSF2425-W	3-1/2" [89 mm]	25-7/8" [657 mm]	28-5/8" [727 mm]	2-1/2" [64 mm]
PSF3025-A	3-1/2" [89 mm]	31-15/16" [811 mm]	34-11/16" [881 mm]	2-1/2" [64 mm]
PSF3025-W	3-1/2" [89 mm]	31-15/16" [811 mm]	34-11/16" [881 mm]	2-1/2" [64 mm]
EXTRUDED SINK FRONT TRAYS (dimensions include HP-XSF-EC-20-W End Caps)				
XSF34-10-W	4-1/2" [114 mm]	35-1/2" [902 mm]	38-1/4" [972 mm]	2-7/8" [114 mm]
XSF72-10-W	4-1/2" [114 mm]	73-3/4" [1,873 mm]	76-1/2" [1,943 mm]	2-7/8" [114 mm]

Dimensions shown are recommended minimum door opening dimensions.