



**KNAPE
& VOGT**



Duet Arm

The Duet offers great functionality along with excellent stability, and is perfect for heavy typing use in customized dual surface or split surface workstations.

7080/7090 series

Features	Benefits
Stable, durable design	Ideal for heavy typing use
Supports large widths	Can be customized for individual workstations
Knob for tilt adjustment	Provides independent tilt adjustment of +/- 15°
New and improved compact spring brake mechanism	Accommodates heavy loads with less possible interference by end user
Embossed arms	Designed for strength and style
Has 16.0" or 19.0" height range adjustment	Designed to alternate between sitting and standing while typing
Counterbalance is field adjustable by installers	Optimized performance
Easy-mount keyhole slots on mounting brackets	Easy to install and remove
Paddle or optional "T" pull control	Easy access height adjustment
Converts conventional single surface workstation into a split level sit to stand work center	Economical solution for a split level workstation
Wherever possible, recycled materials are used to manufacture components	Environmentally friendly
Designed for disassembly and full recyclability	

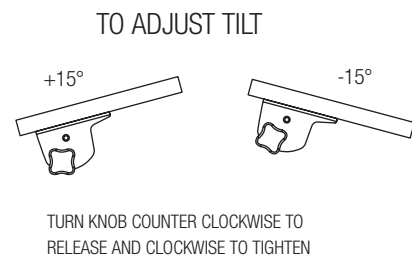
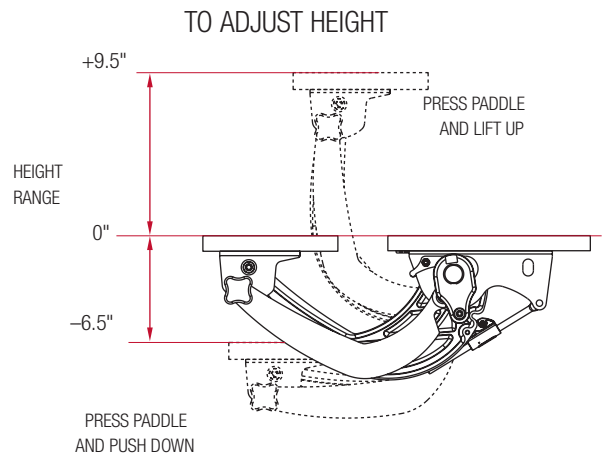
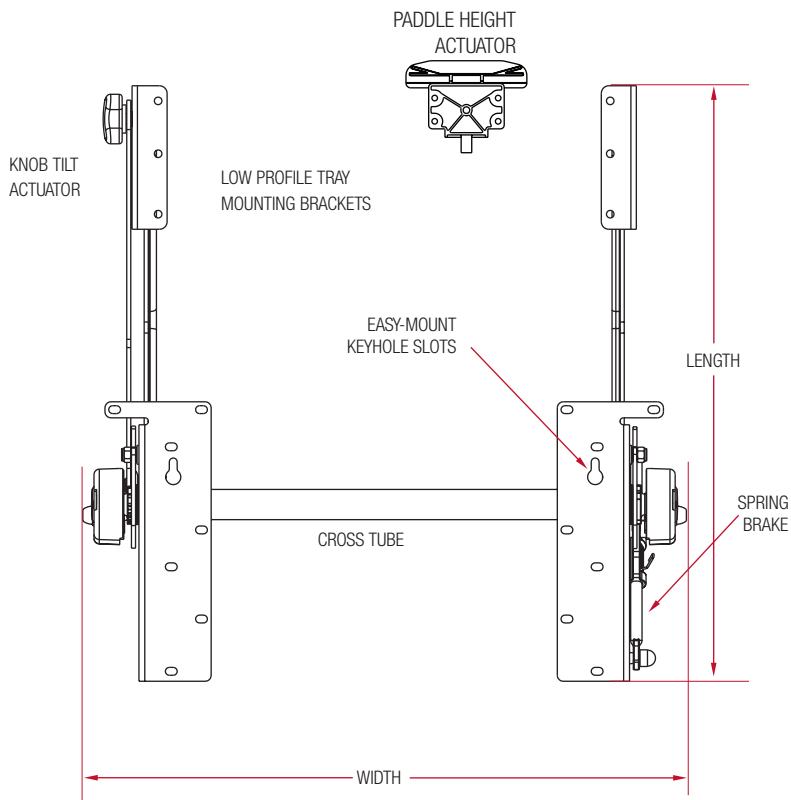

Duet Arm 7080/7090 series

Ancillary Products:

- Use with Knap & Vogt Waterloo CPU holders
- For flat panel displays, specify the Concerto or Xtend flat panel support system

Model	(A) Height Range (B)	Tilt	Length	Width	Weight
7080D2300	+12.5" -6.5"	-15°/+15°	21.1"	23"	17.2 lbs
7080D2700	+12.5" -6.5"	-15°/+15°	21.1"	27"	17.9 lbs
7080D3100	+12.5" -6.5"	-15°/+15°	21.1"	31"	18.2 lbs
7080D3900	+12.5" -6.5"	-15°/+15°	21.1"	39"	19.2 lbs
7090D2300	+9.5" -6.5"	-15°/+15°	19.7"	23"	16.7 lbs
7090D2700	+9.5" -6.5"	-15°/+15°	19.7"	27"	17.0 lbs
7090D3100	+9.5" -6.5"	-15°/+15°	19.7"	31"	17.2 lbs
7090D3900	+9.5" -6.5"	-15°/+15°	19.7"	39"	19.2 lbs

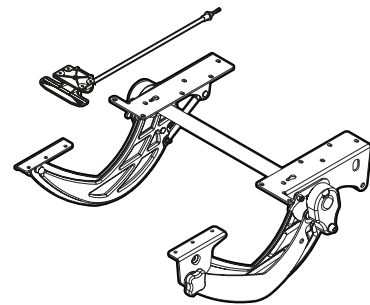

Black

 Exceeds ANSI/BIFMA standards

Notes: 1. Weight = packaged shipping weight per unit. 2. Specifications are subject to change without notice.



2700 Oak Industrial Dr. NE
 Grand Rapids, MI 49505-6026 USA
 1.800.253.1561 | 616.459.3311
 Fax: 877.636.3290
www.kv.com

This and other KV literature is available for download at www.kv.com > Resource Library

Knap & Vogt reserves the right to change product specifications at any time without notice and without incurring responsibility for existing units.
 ©2017 Knap & Vogt. KV and the KV logo are trademarks of Knap & Vogt.

OL2500/0217