



Xtend *Monitor Arm*

Knap & Vogt introduces the Xtend monitor arm. Increase your options for monitor arm placement and access with a class-leading 26.0" reach and 13.0" of usable height adjustment. The new Xtend arm also features a pole-less design for optimal space and storage. Its counterbalanced spring technology allows for a 2 to 14 lbs load and provides a longer life for the product by not relying on gas cylinders.

7818J02 Series

Features & Benefits

Best in class arm provides 26.0" of reach with 13.0" of usable height adjustment.

Visually appealing pole-less monitor arm folds into a 4-3/8" area for more desk space in smaller work environments.

Tool-less clamp installation makes assembly quick and easy.

Flexibility and more options for the end user with a simple, easy-to-use Allen wrench adjustment to counterbalance the weight of the monitor.

With a clamping range of 0" to 2-5/8" (clamp) that is standard for the Xtend, this new arm will fit to any work surface.

Enclosed cable management system hides cables

Counterbalanced spring technology allows for a 2 to 14 lbs load (no gas leakages from use of gas cylinders)

The arm swivels 360° around the base, increasing the options for display position.

Choice of colors – silver, white or black

Made in USA - BAA compliant. Meets GSA bid requirement.

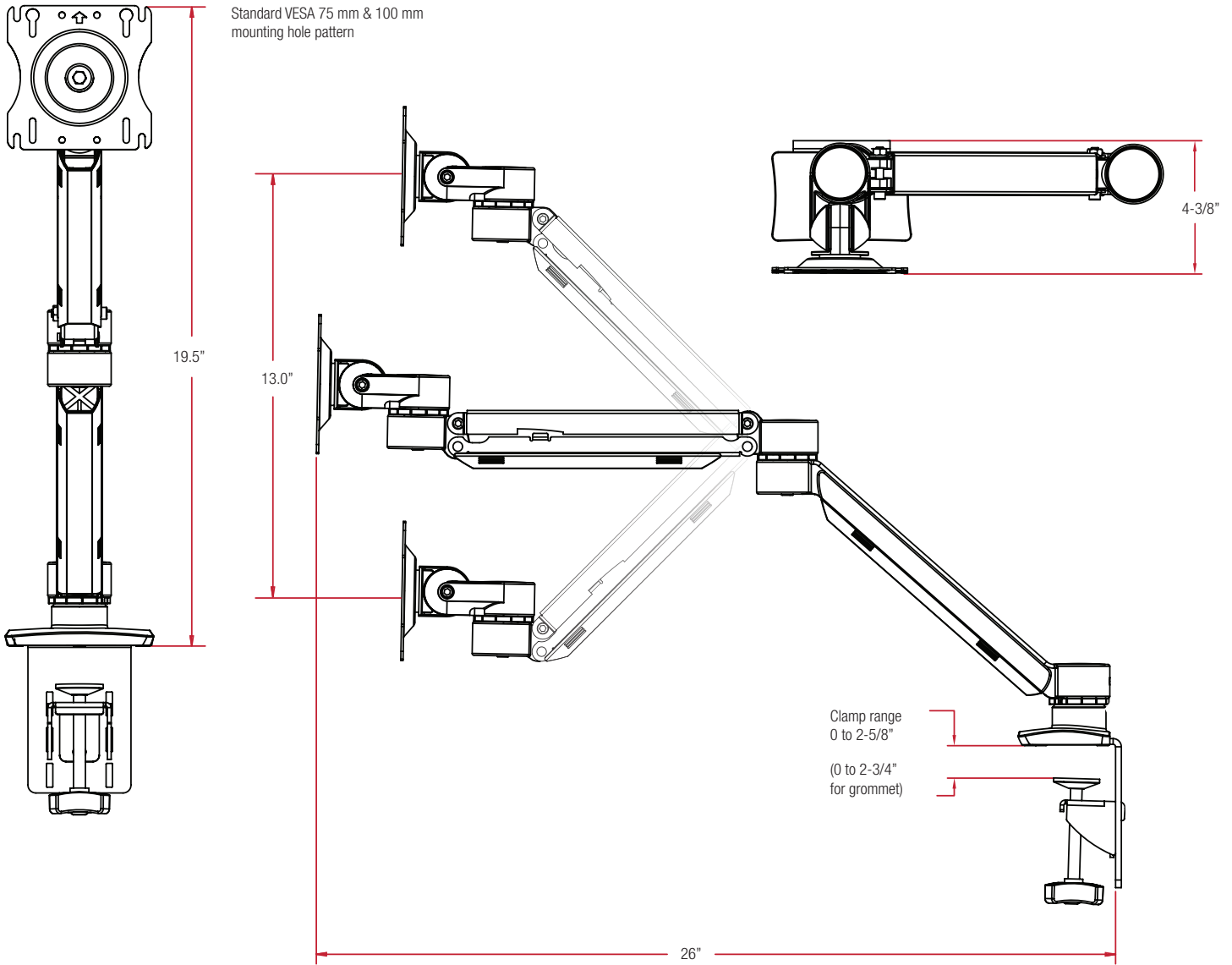

Xtend Monitor Arm 7818J02 Series

Model	Colour	Weight	Description
7818SJ02	Silver	7.8 lbs	Single screen, Double Extension with one Height-Adjustable Segment
7818BJ02	Black	7.8 lbs	Single screen, Double Extension with one Height-Adjustable Segment
7818WJ02	White	7.8 lbs	Single screen, Double Extension with one Height-Adjustable Segment



Finish: Black, White, Silver

Notes: 1. Weight = packaged shipping weight per unit. 2. Specifications are subject to change without notice.