

Mobile Laptop Cart

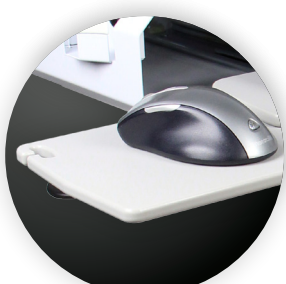

KNAPE & VOGT®

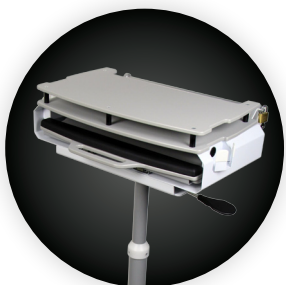

INTELLIGENTLY DESIGNED

- Light-weight with a small footprint ensures ease of mobility, low tip factors as well as compact for maneuvering into small spaces
- Front wheels with pedal locks to allow cart to remain stable and in desired position
- Lithium battery compartment incorporated allowing additional power supply adding to optimal run time for point of care technical applications

INSTALLS IN MINUTES

- Ships pre-assembled resulting in minimal after sale installation costs and reduced downtime for critical care areas
- Actuator handle allows for effortless adjustments optimizing workflow effectiveness for sitting or standing applications

BUILT FOR LIFE

- Maintains high infection control standards with durable anti-microbial agents incorporated into most contact surfaces
- Manufactured of steel aluminium and high-density polyethylene materials supporting high performance, long term usage

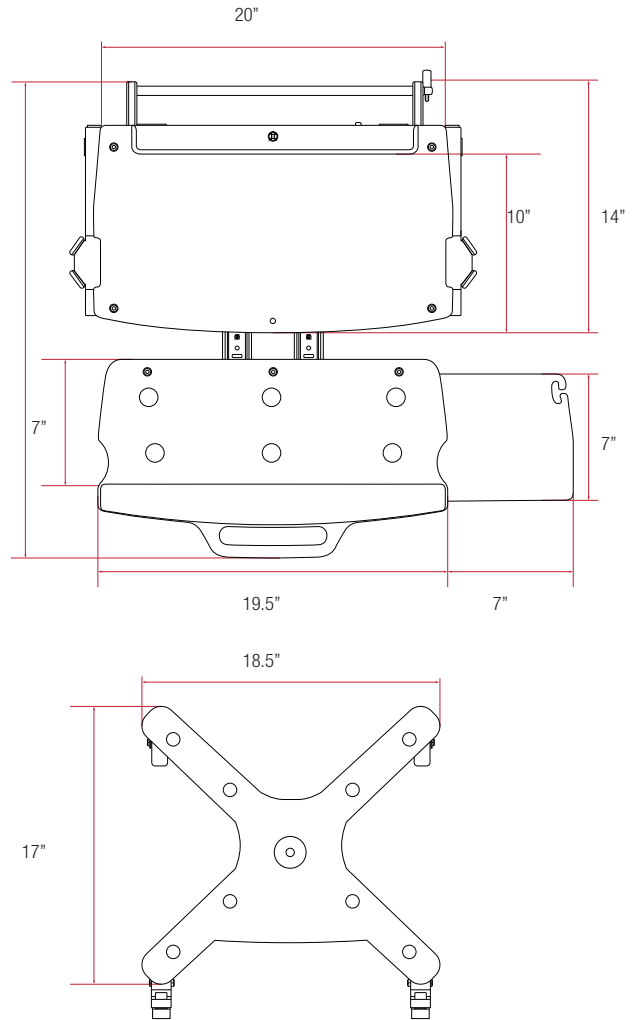
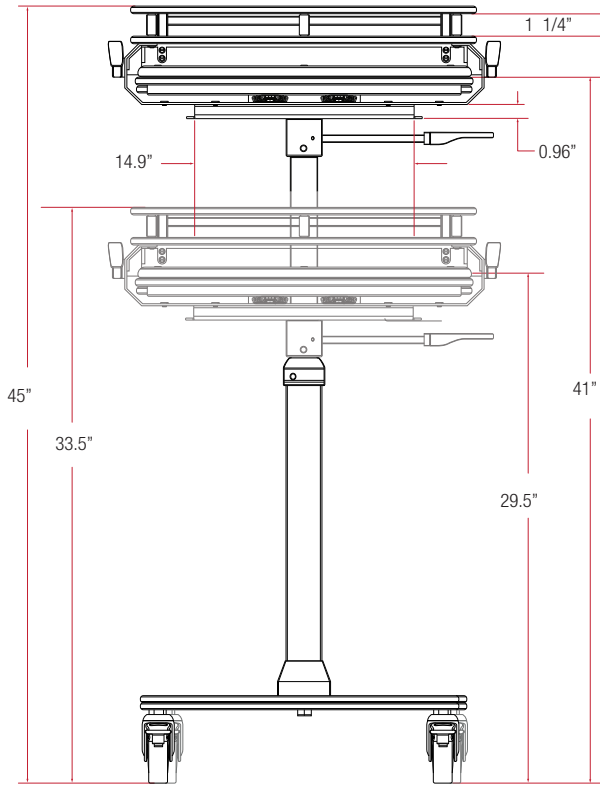

Mobile Laptop Cart



Silver

Finish:



RCHALT70-S Series

Model	Height Adjustment	Max Weight	Castors	Keyboard Tray Extension
RCHALT70-S	33.5-45"	15 lbs.	3"	12.5"

Notes: 1. Weight = packaged shipping weight per unit. 2. Specifications are subject to change without notice. Shipping Weight: 90 lbs. Skid Dimensions: 31" x 31" x 39"



2700 Oak Industrial Dr. NE
 Grand Rapids, MI 49505-6026 USA
 1.800.253.1561 | 616.459.3311
 Fax: 877.636.3290
 www.kv.com

Knappe & Vogt Waterloo - 501 Manitou Drive,
 Kitchener Ontario, Canada N2C 1L2
 1.866.521.8028 | 1.519.748.5060
 Fax 519.748.4783
 www.healthcare.kv.com

OL2547/0314