

KD-110

KD-110

Basic keyboard drawer with palm rest for keyboard and mousing applications.

Features	Benefits
Keyboard drawer 20.0" wide x 10.0" deep	Drawer provides ample space for most keyboard trays
8.0" Diameter swivel only mousing surface with mouse fence and cable manager	Attaches to left or right side of keyboard drawer for ambidextrous mousing
Plastic palm rest	Palm rest providing typing comfort
Precision Ball Bearing Slides with detent feature	Smooth drawer opening and retraction with hold out feature
Adjustable drop height feature provided on slide brackets	Height adjustments of 2.3" to 3.6" for ergonomic placement of drawer under work surface
Mounting hardware provided	Quick and easy installation

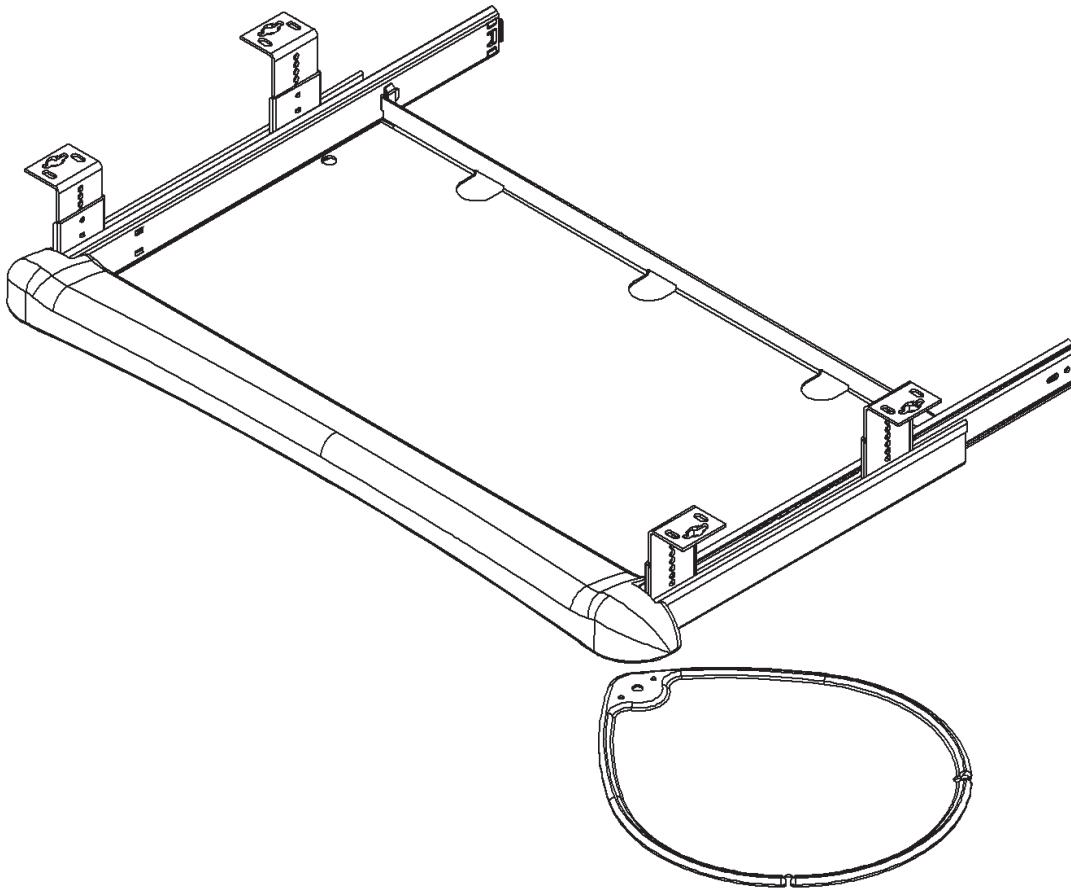

Note: Brackets mount in outboard position under work surface for application widths 23" or greater, and in the inboard position for widths less than 20.75"

KD-110

Basic keyboard drawer system, for keyboard and mousing applications

Ancillary Products:

- Use with Knape & Vogt CPU holders
- For flat panel displays, use the KV Concerto or Xtend series of monitor supports

Model	Keyboard Drawer Width	Keyboard Drawer Depth	Load Rating	Mouse Surface Dia.	Material	Weight
KD-110	20.0"	10.0"	75.0 lbs	8.0"	Painted Steel (Black)	9.5 lbs

Black



Code Compliance: Exceeds ANSI/BIFMA standards

Notes: 1. Weight = packaged shipping weight per unit. 2. Specifications are subject to change without notice.



2700 Oak Industrial Dr. NE
 Grand Rapids, MI 49505-6026 USA
 1.800.253.1561 | 616.459.3311
 Fax: 877.636.3290
www.kv.com

This and other KV literature is available for download at www.kv.com > Resource Library

Knape & Vogt reserves the right to change product specifications at any time without notice and without incurring responsibility for existing units.
 ©2017 Knape & Vogt. KV and the KV logo are trademarks of Knape & Vogt.

OL2623/1017