

Server Rack

Market Need:

- A sliding system that allows full access to hardware for serviceability

Design Challenges:

- Access to server hardware
- Allow for largest possible server chassis footprint
- Ease of installation
- Cable management
- Support heavy weight loads

KV Solution:

Features incorporated into server rack slides include:

- Access to server hardware with over-travel
- Low profile, ultra slim width
- Universal, tool-less bracket for round or square holes
- Ball retainer lock for ease of installing inner slide member
- Cable management accessory that manages cables in the open and close positions
- Meets dynamic load rating of 88 lbs. (40kg) and UL static load rating of 205 lbs. (95kg)

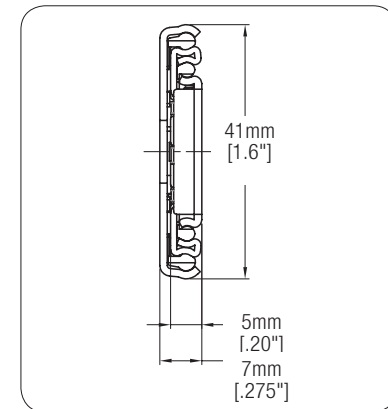

- 41mm (1.6") tall
- 7mm (.275") wide
- 3 member over travel slide

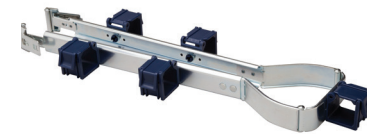

Cable Management Accessory (CMA)
with Quick-Release connector

Coming in 2017: 82mm (3.2") slide